

straub[®] 

2010

the original

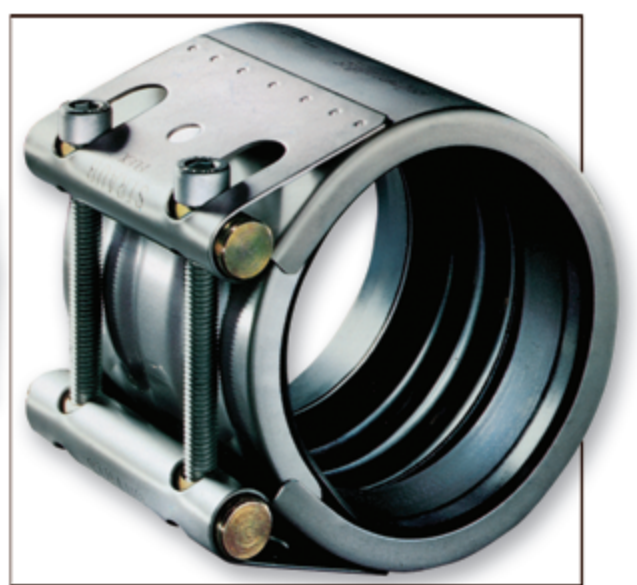
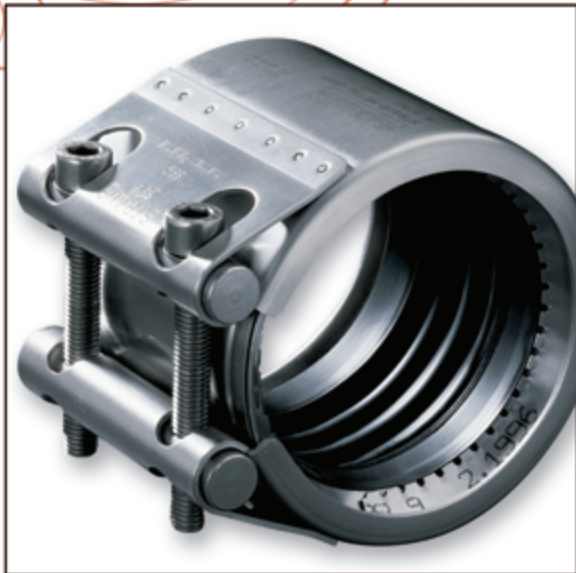

straub couplings

Trusted Pipe-Joining Solutions For Over Forty Years



STRAUB Pipe Couplings

PROGRESSIVE SEALING EFFECT

STRAUB-GRIP

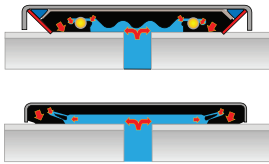

STRAUB-FLEX

PROGRESSIVE ANCHORING EFFECT

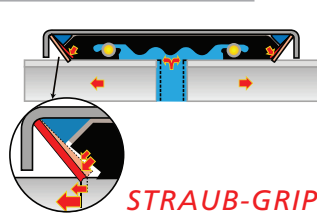

STRAUB-GRIP

SIMPLE – RAPID

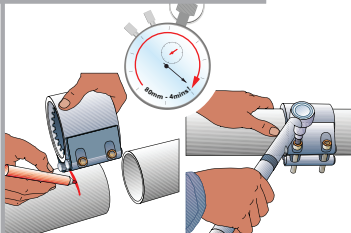

VIBRATION AND NOISE DAMPING



AXIAL RESTRAINT

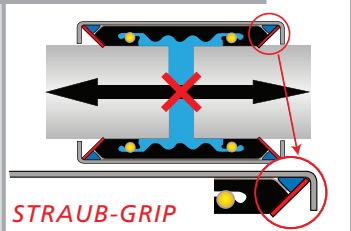

STRAUB-GRIP

AXIAL FLEXIBILITY

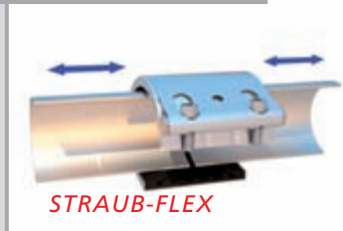

STRAUB-FLEX

FLEXIBILITY

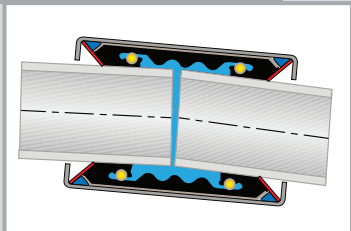

SPACE SAVING



- Joins different pipe materials
- Progressive lip seal technology
- Eliminates Welding. No Special tools Required.
- Detachable and reusable
- Fastest and easiest way to join pipes.
- Saves: Time - Labor - Money
- Over 180 approvals worldwide

straub 
the original

an OAliaxis company

The dependable plain end coupling system that **SAVES TIME, SAVES MONEY** and **SAVES SPACE**.
 The STRAUB coupling is a patented mechanical coupling system for joining plain end pipe in sizes ¾" through 144".

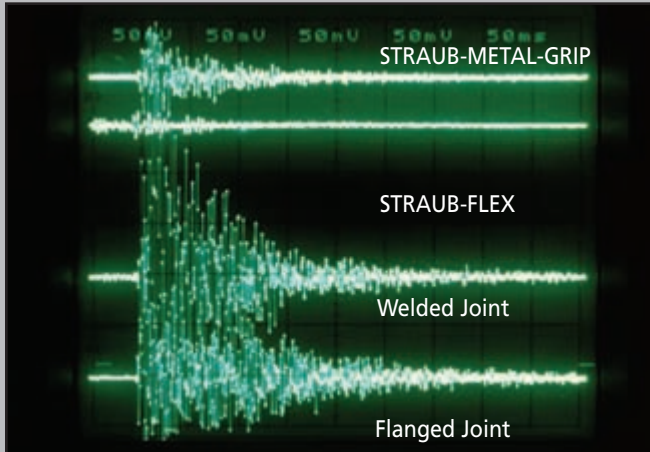

Noise & Vibration Damping



Angular Deflection: 20 degrees
 Pressure: 300 PSI

FAST AND ECONOMICAL

- ◆ Stab fit design - ready to install
- ◆ Fits Plain-End Pipes
- ◆ No Special Tools Required
- ◆ Reusable

The STRAUB system eliminates the need for any pipe end preparation, saving time and money. Assembly requires only a torque wrench to secure the pipe joint. The unique low profile design closes around the circumference of the pipe or tube, creating a leak tight seal without the need for lubricant. STRAUB couplings are used to join virtually any plain end pipe or tube including steel, stainless steel, ductile iron, FRP, PVC, CPVC, C900, CPP, concrete pipe, copper, and CuNi.

FEATURES & BENEFITS

UNIVERSAL USE

- Suitable for almost any pipe material
- Joins pipes of the same or dissimilar materials
- Suitable for pressure, vacuum or suction lines
- Leakproof joint, due to the pressure responsive gasket
- Quick and simple repairs to existing pipe lines

ECONOMICAL

- Pre-assembled, stab-fit design ensures simple, rapid installation
- For use on plain-end pipes without the need for costly pipe end preparation
- Simply cut pipes to length, center coupling and tighten bolts
- Suitable for thick or thin wall pipes
- Needs only a torque wrench - no other special tools required

RELIABLE

- Stress-free, flexible pipe joint
- Compensates for axial movement and angular deflection
- Pressure-resistant and leak-proof even with inaccurate pipe assembly
- Dampens water-hammer, vibration and structure-borne noise

EASY HANDLING

- Detachable and re-usable, maintenance free
- Eases pipe alignment problems
- Simple and quick to install, reduces installation costs
- No heat or fire hazard, can be fitted in fire risk or confined spaces without special equipment or permits

DURABLE

- Progressive sealing effect, higher pressures reinforce the seal
- Axial restraint versions available, prevents pipe pull-out
- Corrosion resistant; all stainless steel construction
- Good resistance to temperature and chemicals
- Reusable

SPACE-SAVING

- Compact design, saves space and allows pipes to be compactly installed
- Allows the use of low profile pipe insulation
- Can be accessed in confined areas, coupling can be rotated to provide ease of access to bolts
- Light weight

THE STRAUB CONCEPT

PRESSURE RESPONSIVE SEAL

- ◆ Seal is reinforced by increasing line pressure, ensuring long life performance.
- ◆ Seals on rough pipe surfaces
- ◆ No lubrication of gasket is required
- ◆ Pressure or vacuum service
- ◆ Absorbs noise and vibration
- ◆ Low torque/compression ensures long service life

COMPACT DESIGN

- ◆ Saves Space
- ◆ Allows pipes to be closely grouped
- ◆ Allows low profile installation
- ◆ Corrosion resistant construction

EASE OF HANDLING & ASSEMBLY

- ◆ Light weight
- ◆ Simple and quick to install
- ◆ Stab fit, no need to disassemble
- ◆ Low torque required
- ◆ No pipe end preparation
- ◆ Reusable
- ◆ Never needs retightening
- ◆ No welding



STRAUB-METAL-GRIP & STRAUB-GRIP-L

The STRAUB-GRIP-L and STRAUB-METAL-GRIP couplings join plain end pipes with axial restraint. STRAUB-GRIP-L and STRAUB-METAL-GRIP provide pull out resistance in excess of the coupling's rated working pressure. Whether for pressure or suction lines, thick or thin wall pipe, the STRAUB-GRIP-L and STRAUB-METAL-GRIP couplings are installed quickly, safely and economically. Due to the unique design of the teeth, as internal pressure increases, the anchoring effect is progressively increased. The engagement of the teeth into the pipe's outside surfaces provides for electrical conductivity across the pipe joint.

STRAUB-FLEX

The STRAUB-FLEX coupling will join virtually any plain end pipe. Whether pressure or suction lines, thick or thin wall pipe, the STRAUB-FLEX coupling is installed quickly, safely and economically. STRAUB-FLEX couplings can accommodate pipe system expansion and contraction movement as well as angular deflection. STRAUB-FLEX couplings require the pipes to be axially restrained and are an economical alternative to rubber and metal expansion joints.

STRAUB-OPEN-FLEX

The STRAUB-OPEN-FLEX is a split coupling version of STRAUB-FLEX, offering all the STRAUB-FLEX benefits, plus being able to make repairs to in service pipe lines. With the STRAUB-OPEN-FLEX coupling, leaks due to faulty weld joints, pitting holes and short cracks can be temporarily or permanently repaired with minimal down time. The split gasket design can be wrapped around the pipe and installed without pipe disassembly. Assembly tools are available to ease the installation of the STRAUB-OPEN-FLEX coupling. When used to join pipe ends the STRAUB-OPEN-FLEX coupling provides the same flexibility features as the STRAUB-FLEX design. STRAUB-OPEN-FLEX couplings require the pipes to be axially restrained.

All STRAUB couplings require the correct use of a torque wrench for a safe and proper installation. STRAUB couplings must be torqued to the specified value as printed on each individual coupling. Failure to do so can result in injury or death.



THE BASIC CONCEPT

Two types of Straub Couplings

- **STRAUB-GRIP**

PULL OUT RESISTANT

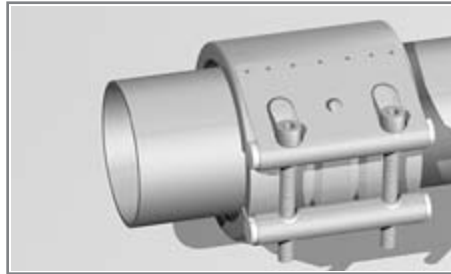

- **STRAUB-FLEX/
OPEN-FLEX**

NOT PULL OUT RESISTANT

STRAUB-GRIP

STRAUB-GRIP type couplings utilize a patented grip ring and are pull-out resistant to a minimum of four times the agency approval working pressure.*

STRAUB-FLEX/-OPEN-FLEX

STRAUB-FLEX type couplings do not have a grip ring and are therefore suitable for applications requiring axial movement due to thermal growth or other factors. STRAUB-FLEX couplings are a suitable replacement for expansion joints.

STRAUB-OPEN-FLEX couplings are a split case version of the standard STRAUB-FLEX coupling.

STRAUB-GRIP

PULL OUT RESISTANT



STRAUB-FLEX/-OPEN-FLEX

NOT PULL OUT RESISTANT



STRAUB-GRIP-L
PAGE 8



STRAUB-METAL-GRIP
PAGE 9



STRAUB-FLEX
PAGE 10-15



STRAUB-OPEN-FLEX
PAGE 10-15

Other GRIP types on pages: 14 & 16.

* Marine Approval Societies

MATERIAL SPECIFICATIONS

Components	COUPLING TYPES							
	W1		W2		W4		W5	
	DIN	AISI	DIN	AISI	DIN	AISI	DIN	AISI
Casing	1.0570, galvanized	1024	1.4301	304/316	1.4301	304	1.4571	316 Ti/316L
Bolts	1.7220	4135	1.7220	304/316	1.4404/1.4435	316L	1.4404/1.4435	316L
Bars	1.0737 galvanized	12L14	1.0737, galvanized	12L14	1.4404/1.4435	316L	1.4404/1.4435	316L
Anchoring ring	1.43110	301	1.4310/1.4301	301	1.4310/1.4301	301	1.4310	301
Strip insert (option)	1.44350	316L	1.4435	316L	1.4435	316L	1.4435	316L

Optional strip insert - AISI Type 316L Stainless Steel, HDPE or PVDF.

For casing designations refer to the size and pressure indicated in the STRAUB-FLEX and STRAUB-OPEN-FLEX selection chart.

All materials meets ANSI / AISI standards.

GASKET SPECIFICATIONS

GASKET MATERIAL:

EPDM -4° to +212°F*

Nitrile -4° to +180°F

Viton®
-4° to +302°F

GENERAL SERVICE APPLICATION:

Water, dilute acids, alkalis, salts, and many chemical services not involving hydrocarbons, oils or gases. Excellent oxidation resistance.
NOT FOR USE WITH HYDROCARBONS.

Petroleum products, vegetable oils, mineral oils and air contaminated with petroleum oils.
H-NBR available for higher temperature applications.

High temperature resistance to oxidizing acids, petroleum oils, hydraulic fluids, halogenated hydrocarbons and lubricants. (Not available in all sizes/types).

* Maximum temperature limit is 212°F (100°C) with EPDM gasket material and strip insert.

Higher temperature limits may be allowed subject to specific factory approval.

For specific chemical recommendations, please consult your Straub Professional.

HOW TO ORDER (Example)

PRODUCT DESIGNATION	NOMINAL PIPE SIZE OR PIPE O.D.	PIPE DESIGNATION	LOCK PARTS	GASKET MATERIAL	OPTIONAL STRIP INSERT
STRAUB-GRIP-L	10"	IPS	Stainless Steel "SS"	E - EPDM	SI
STRAUB-METAL-GRIP		CTS	Galvanized "G"	N - Nitrile	PVDF
STRAUB-FLEX + (casing type)		AWWA		V - Viton®	T
STRAUB-OPEN-FLEX + (casing type)		Other (Supply actual Pipe OD)			

Example: STRAUB-GRIP-L -10 - IPS - SS- E - SI

Represents STRAUB-GRIP-L style coupling for 10" IPS pipe with stainless steel lock parts, an EPDM gasket and the optional stainless strip insert.



INTERNATIONAL CERTIFICATION



Some of the approvals for STRAUB couplings are shown above. STRAUB couplings are approved and listed by a large number of national and international agencies in various industries, including water engineering, fire protection, mining, shipbuilding & offshore, gas, petrochemical and general industry. Contact STRAUB for details. STRAUB is an ISO 9001 certified manufacturing facility and 14001 certified. US Patent Numbers: 5 280 969, 5 137 305, 3 877 733, 5 273 322, 4 119 333, 4 629 217, 5 280 970, 4 664 422, 5 310 223, 5 203 594.

STRAUB Couplings meet or exceed the requirements of ASTM 1476 & ISO/NP-15837/ 15838 & ANSI / AWWA C227-07

INDUSTRIES SERVED

- Shipbuilding & Offshore
- Water & Wastewater
- Gas Turbines
- Engine Manufacturing
- Locomotives
- Ultra - Filtration
- Compressors
- Landfills

COUPLING CHART NOTES

1	2		3	4		5		6		7	8
	PIPE OUTSIDE DIAMETER			Working Pressure	COUPLING DIMENSIONS		ASSEMBLED DIMENSIONS		MAXIMUM DISTANCE BETWEEN PIPE ENDS (Rmax.)		
Nominal IPS	Actual	OD Range +/-	psi/bar		B	C	DV	KV	Without Strip insert	With Strip insert	Torque Rate
Inches	In./mm	In./mm		In./mm	In./mm	In./mm	In./mm	In./mm	In./mm	In./mm	

1. STRAUB Couplings are identified by either the nominal IPS pipe size, CTS tube size, or AWWA ductile iron pipe size in inches, or the pipe/tube OD in inches and millimeters.
2. Nominal outside diameter of pipe or tube that coupling will fit.
3. Maximum line pressure, including surge, to which the pipe joint should be subjected. Note: For a one-time field test the maximum joint working pressure may be increased to 1^{1/2} times the figure shown.
4. Coupling dimensions for reference purposes only.
5. The DV and KV assembled dimensions provided for reference.
6. Maximum allowable distance between pipe ends when assembled (with or without strip inserts).
7. Required Torque Rate. This is also printed on all couplings. Torque rate is suitable for all recommended pipe materials
8. Weight of complete coupling.

(For STRAUB-GRIP-L and STRAUB-METAL-GRIP couplings, an additional pressure rating column is shown. This is for applications that require authorization by Marine Approval Agencies such as Lloyds, ABS, DNV, etc.)



Axial-Restraint Pipe Coupling

STRAUB-GRIP-L COUPLING



For IPS Outside Diameter Pipe

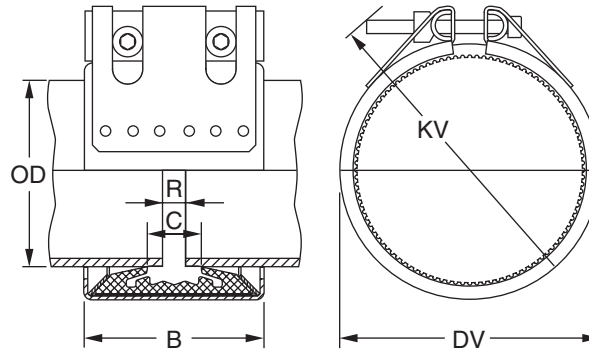

3/4" - 2" couplings with 1 Bolt only.

STRAUB-GRIP L

Nominal IPS Inches	PIPE OUTSIDE DIAMETER		Working Pressure psi/bar	Agency Approved Pressure* psi/bar	COUPLING DIMENSIONS		ASSEMBLED DIMENSIONS		MAXIMUM DISTANCE BETWEEN PIPE ENDS (Rmax.)		Torque Rate Ft.lbs./Nm	Approx. Weight Each Lbs./kg
	Actual In./mm	OD Range In./mm			B	C	DV	KV	Without Strip insert In./mm	With Strip insert In./mm		
3/4	1.050 26.9	1.04 - 1.08 26.4 - 27.4	670 46	232 16.0	1.8 46	0.7 18	1.7 43	2.8 71	0.2 5	0.4 10	0.4 0.2	
1	1.315 33.7	1.31 - 1.35 33.2 - 34.2	550 38	232 16.0	1.8 46	0.7 18	2 51	3 76	0.2 5	0.4 10	0.4 0.2	
1 1/4	1.660 42.4	1.65 - 1.69 41.9 - 42.9	400 30	232 16.0	2.4 61	1 25	2.4 61	3.7 94	0.2 5	0.4 10	0.8 0.4	
1 1/2	1.900 48.3	1.88 - 1.92 47.7 - 48.7	440 30	232 16.0	2.4 61	1 25	2.6 66	3.9 99	0.2 5	0.4 10	0.9 0.4	
2	2.375 60.3	2.35 - 2.40 59.6 - 60.9	320 22	232 16.0	3 76	1.5 38	3.1 79	4.3 109	0.4 10	0.6 15	1.2 0.5	
2 1/2	2.875 73.0	2.85 - 2.90 72.3 - 73.6	450 31	232 16.0	3.7 94	1.6 41	3.9 99	5.3 135	0.4 10	0.6 15	2.7 1.2	
3	3.500 88.9	3.46 - 3.54 87.8 - 89.9	450 31	232 16.0	3.7 94	1.6 41	4.4 112	5.9 150	0.4 10	1.0 25	2.6 1.2	
3 1/2	4.000 101.6	3.96 - 4.04 100.5 - 102.6	320 22	232 16.0	3.7 94	1.4 36	5.1 130	6.3 160	0.6 15	0.6 15	3.3 1.5	
4	4.500 114.3	4.46 - 4.54 113.2 - 115.3	232 16	232 16.0	3.7 94	1.6 41	5.4 137	6.7 170	0.4 10	1 25	3.2 1.5	
5	5.500 139.7	5.51 - 5.62 139.9 - 142.7	232 16	232 16.0	4.3 109	2.1 53	6.5 165	8.3 211	0.4 10	1.4 36	5.7 2.6	
6	6.625 168.3	6.56 - 6.69 166.6 - 169.9	232 16	188 13.0	4.3 109	2.1 53	7.6 193	9.1 231	0.4 10	1.4 36	6.4 2.9	
8	8.625 219.1	8.54 - 8.71 216.9 - 221.2	232 16	145 10.0	5.6 142	3.1 79	9.8 249	11.6 295	0.4 10	1.4 36	13.0 5.9	
10	10.750 273.0	10.65 - 10.85 270.5 - 275.5	100 7	67 4.6	5.5 140	3.1 79	11.9 302	13 330	0.4 10	1.4 36	12.7 5.8	
12	12.750 323.9	12.62 - 12.87 320.5 - 326.8	70 5	52 3.6	5.5 140	3.1 79	13.9 353	15 381	0.4 10	1.4 36	14.3 6.5	
14	14.000 355.6	13.86 - 14.13 352.0 - 358.9	60 4	45 3.1	5.5 140	3.1 79	15.2 386	16.3 414	0.4 10	1.4 36	15.4 7.0	
16	16.000 406.4	15.85 - 16.16 402.5 - 410.4	45 3	35 2.4	5.5 140	3.1 79	17.1 434	18.3 465	0.4 10	1.4 36	16.9 7.7	
18	18.00 457.2	17.81 - 18.17 452.3 - 461.5	30 2.0	30 2.0	5.5 140	3.1 79	19.2 488	20.5 521	0.4 10	1.4 36	18.5 8.4	
20	20.00 508.0	19.82 - 20.18 503.4 - 512.5	30 2.0	30 2.0	5.5 140	3.1 79	21.2 538	22.4 569	0.4 10	1.4 36	20.2 9.2	
22	22.00 558.8	21.83 - 22.19 554.4 - 563.6	30 2.0	30 2.0	5.5 140	3.1 79	23.2 589	24.4 620	0.4 10	1.4 36	21.8 21.8	
24	24.00 609.6	23.82 - 24.17 605.0 - 613.9	15 1.0	15 1.0	5.5 140	3.1 79	25.2 640	26.4 671	0.4 10	1.4 36	23.3 10.6	

See label on coupling for proper torque rates

*Agency approved pressures are for applications that require authorization of Classification Societies, such as Marine Approval Bodies.

Other sizes available upon request.

3/4" - 8": W5 only
10" - 24": W2 or W5



All STRAUB couplings require the correct use of a torque wrench for a safe and proper installation. STRAUB couplings must be torqued to the specified value as printed on each individual coupling. Failure to do so can result in injury or death.



Axial-Restraint Pipe Coupling

STRAUB-METAL GRIP COUPLING



For IPS Outside Diameter Pipe

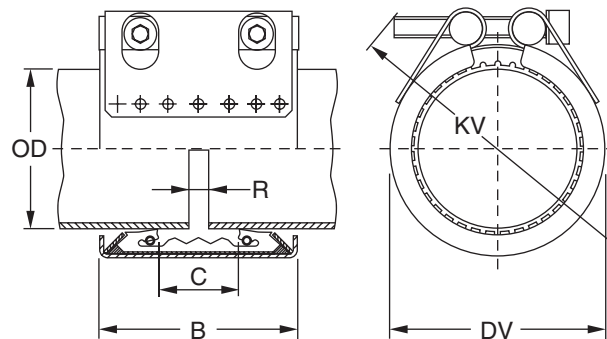

STRAUB-METAL GRIP

Nominal IPS	PIPE OUTSIDE DIAMETER		Working Pressure	Agency Approved Pressure*	COUPLING DIMENSIONS		ASSEMBLED DIMENSIONS		MAXIMUM DISTANCE BETWEEN PIPE ENDS (Rmax.)		Torque Rate	Approx. Weight Each
	Actual	OD Range +/-			B	C	DV	KV	Without Strip insert	With Strip insert		
Inches	In./mm	In./mm	psi/bar	psi/bar	In./mm	In./mm	In./mm	In./mm	In./mm	In./mm	Ft.lbs./Nm	Lbs./kg
1	1.315	1.31 - 1.35	900	232	2.6	0.7	1.7	2.6	0.2	0.6	7.5	0.7
	33.7	33.2 - 34.2	62.1	16.0	66	18	43	66	5	15	10	0.3
1¼	1.660	1.65 - 1.69	770	232	2.4	0.8	2.4	3.5	0.2	0.6	11	1.1
	42.4	41.9 - 42.9	53.1	16.0	61	20	61	89	5	15	15	0.5
1½	1.900	1.88 - 1.92	640	232	2.4	0.8	2.7	3.7	0.2	0.6	11	1.1
	48.3	47.7 - 48.7	44.1	16.0	61	20	69	94	5	15	15	0.5
2	2.375	2.35 - 2.40	540	232	3	1.5	3.2	4.3	0.4	1.0	15	1.7
	60.3	59.6 - 60.9	37.2	16.0	76	38	81	109	10	25	20	0.8
3	3.500	3.46 - 3.54	540	232	3.7	1.5	4.6	5.7	0.4	1.0	26	3.2
	88.9	87.8 - 89.9	37.2	16.0	94	38	117	145	10	25	35	1.5
4	4.500	4.46 - 4.54	490	232	3.7	1.5	5.5	6.5	0.4	1.0	26	3.8
	114.3	113.2 - 115.3	33.8	16.0	94	38	140	165	10	25	35	1.7
5	5.500	5.44 - 5.56	470	232	4.3	1.7	6.6	7.9	0.6	1.4	45	7.8
	139.7	138.7 - 141.2	32.4	16.0	109	43	168	201	15	36	60	3.5
6	6.625	6.56 - 6.69	420	232	4.3	1.7	7.9	9.1	0.6	1.4	45	8.8
	168.3	166.6 - 169.9	28.8	16.0	109	43	201	231	15	36	60	4.0
8	8.625	8.54 - 8.71	380	232	5.9	2.4	10.2	11.6	0.6	1.4	75	20.6
	219.1	216.9 - 221.2	26.2	16.0	150	61	259	295	15	36	100	9.4
10	10.750	10.65 - 10.85	300	174	5.8	2.6	12.5	14.6	0.6	1.4	135	33.5
	273.0	270.5 - 275.5	20.7	12.0	147	66	318	371	15	36	180	15.2
12	12.750	12.62 - 12.87	250	145	5.8	2.6	14.5	16.5	0.6	1.4	170	37.8
	323.9	320.5 - 326.8	17.2	10.0	147	66	368	419	15	36	230	17.2
14	14.000	13.86 - 14.13	250	116	5.8	2.6	15.8	17.7	0.6	1.4	170	40.3
	355.6	352.0 - 358.9	17.2	8.0	147	66	401	450	15	36	230	18.3
16	16.000	15.85 - 16.16	200	116	5.8	2.6	17.8	19.7	0.6	1.4	170	54.3
	406.4	402.5 - 410.4	13.8	8.0	147	66	452	500	15	36	230	24.7
18	18.000	17.81 - 18.19	120	94	5.8	2.6	20	22	0.6	1.4	185	59.4
	457.2	452.3 - 462.0	8.3	6.4	147	66	508	559	15	36	250	27.0
20	20.000	19.80 - 20.20	90	80	5.8	2.6	22	24	0.6	1.4	185	64.2
	508.0	502.9 - 513.0	6.2	5.5	147	66	559	610	15	36	250	29.2
24	24.000	23.80 - 24.19	70	65	5.8	2.6	26	28	0.6	1.4	221	74.2
	609.6	604.5 - 614.4	4.9	4.4	147	66	660	711	15	36	300	33.7

*Agency approved pressures are for applications that require authorization of Classification Societies, such as Marine Approval Bodies.

Other sizes available upon request.

1" - 8": W2 or W4
10" - 24": W1 only



All STRAUB couplings require the correct use of a torque wrench for a safe and proper installation. STRAUB couplings must be torqued to the specified value as printed on each individual coupling. Failure to do so can result in injury or death.



STRAUB-OPEN-FLEX-IL

Non-Axial Restraint Pipe Coupling

STRAUB-FLEX 1L & STRAUB-OPEN-FLEX 1L COUPLING

For IPS Outside Diameter Pipe

- Pipes must be properly anchored and supported.
- STRAUB-FLEX & STRAUB-OPEN-FLEX Couplings are **NOT** pull-out resistant.

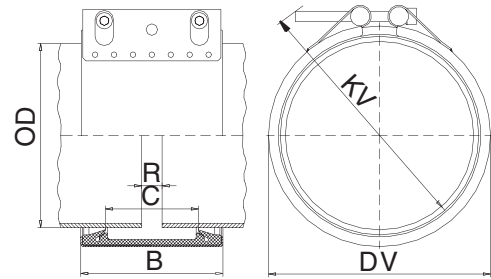

STRAUB-FLEX 1L & STRAUB-OPEN-FLEX 1L

Nominal IPS Inches	PIPE OUTSIDE DIAMETER		Working Pressure psi/bar	COUPLING DIMENSIONS		ASSEMBLED DIMENSIONS		MAXIMUM DISTANCE BETWEEN PIPE ENDS (Rmax.)		Approx. Weight Each Lbs./kg
	Actual In./mm	OD Range +/- In./mm		B In./mm	C In./mm	DV In./mm	KV In./mm	Without Strip insert In./mm	With Strip insert In./mm	
1½	1.900	1.85 - 1.95	363	3.0	1.4	2.8	3.3	0.2	0.6	1.1
	48.3	46.9 - 49.5	25	76	35	71	85	5	15	0.5
2	2.375	2.32 - 2.42	232	3.0	1.4	3.2	3.7	0.2	0.6	1.3
	60.3	58.9 - 61.4	16.0	76	35	81	95	5	15	0.6
2½	2.875	2.81 - 2.93	232	3.0	1.4	3.2	3.7	0.2	0.6	1.76
	73.0	71.3 - 74.4	16.0	76	35	81	95	5	15	.8
3	3.500	3.44 - 3.56	232	3.7	2.0	4.4	4.9	0.2	1.0	2.1
	88.9	87.3 - 90.4	16.0	94	51	112	125	5	25	1.0
4	4.500	4.43 - 4.57	232	3.7	2.0	5.4	5.9	0.2	1.0	2.3
	114.3	112.5 - 116.0	16.0	94	51	137	150	5	25	1.1
5	5.500	5.49 - 5.36	232	4.2	2.4	6.4	7.1	0.2	1.4	3.1
	139.7	139.4 - 136.1	16.0	107	61	163	180	5	35	1.4
6	6.625	6.54 - 6.71	232	4.2	2.4	7.5	8.1	0.2	1.4	3.7
	168.3	166.1 - 170.4	16.0	107	61	191	206	5	35	1.7

* W2 or W5 OPEN-FLEX 1L in hinged style only

Other sizes available upon request.

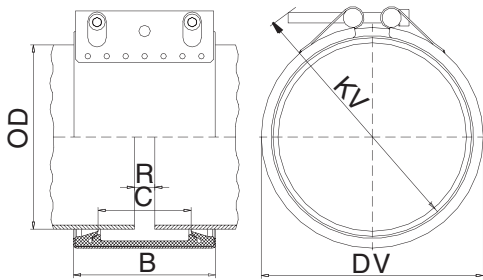

STRAUB-FLEX & STRAUB-OPEN-FLEX COUPLING

Coupling Dimensions

STRAUB-FLEX 2 & STRAUB-OPEN-FLEX 2 Dimensions

STRAUB-FLEX or STRAUB-OPEN-FLEX TYPE	COUPLING DIMENSIONS		ASSEMBLED DIMENSIONS DV	Maximum Distance Between Pipe Ends (Rmax.)	
	B	C		Without Strip insert	With Strip insert
	In./mm	In./mm		In./mm	In./mm
2L	5.4	3.6	OD+.91	0.39	1.38
	138	91	OD+23	10	35
2LS	5.5	3.6	OD+.95	0.39	1.38
	140	91	OD+24	10	35
2LU	5.5	3.6	OD+.95	0.39	1.38
	141	91	OD+24	10	35
2H	5.6	3.6	OD+1.02	0.39	1.38
	142	91	OD+26	10	35
2XS	5.8	3.6	OD+1.26	0.39	1.38
	148	91	OD+32	10	35

* W1, W2, or W5. consult factory for details

OPEN-FLEX 2 not available in hinged style

STRAUB-FLEX 3 & STRAUB-OPEN-FLEX 3 Dimensions

STRAUB-FLEX or STRAUB-OPEN-FLEX TYPE	COUPLING DIMENSIONS		ASSEMBLED DIMENSIONS DV	Maximum Distance Between Pipe Ends (Rmax.)	
	B	C		Without Strip insert	With Strip insert
	In./mm	In./mm		In./mm	In./mm
3L	8.3	5.0	OD+1.42	0.59	2.36
	210	127	OD+36	15	60
3LS	8.3	5.0	OD+1.46	0.59	2.36
	210	127	OD+37	15	60
3LU	8.4	5.0	OD+1.50	0.59	2.36
	213.4	127	OD+38	15	60
3H	8.35	5.0	OD+1.5	0.59	2.36
	212	127	OD+38	15	60
3X	8.58	5.0	OD+1.73	0.59	2.36
	218	127	OD+44	15	60

* W1, W2, or W5. consult factory for details

OPEN-FLEX 3 not available in hinged style



All STRAUB couplings require the correct use of a torque wrench for a safe and proper installation. STRAUB couplings must be torqued to the specified value as printed on each individual coupling. Failure to do so can result in injury or death.

STRAUB-FLEX 2 & STRAUB-OPEN-FLEX 2 COUPLING

For IPS Outside Diameter Pipe

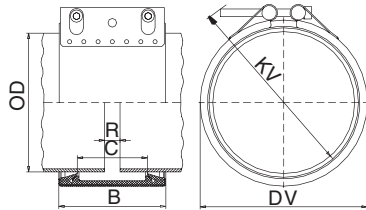

STRAUB-FLEX

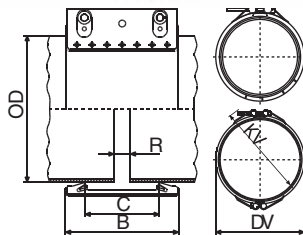

STRAUB-OPEN-FLEX

(Slotted Type)

Non-Axial Restraint Pipe Couplings

- Pipes must be properly anchored and supported.
- STRAUB-FLEX & STRAUB-OPEN-FLEX Couplings are **NOT** pull-out resistant.

STRAUB-OPEN-FLEX Installation tool available.



All STRAUB couplings require the correct use of a torque wrench for a safe and proper installation. STRAUB couplings must be torqued to the specified value as printed on each individual coupling. Failure to do so can result in injury or death.

STRAUB-FLEX 2 & STRAUB-OPEN-FLEX 2 Selection Chart

Nominal IPS Pipe Size (Inches)	Pipe Outside Diameter In./mm	2L Working Pressure psi/bar	2LS Working Pressure psi/bar	2LU Working Pressure psi/bar	2H Working Pressure psi/bar	2XS Working Pressure psi/bar
8	8.625	145	198	367		
	219.1	10	13.5	25		
10	10.750	116	161	323	367	
	273.1	8	11	22	25	
12	12.750	102	132	264	367	
	323.9	7	9.5	18.5	25	
14	14.000	87	117	249	367	
	355.6	6	8.5	17	25	
16	16.000	80	102	220	323	367
	406.4	5.5	7.5	15	22	25
18	18.000	73	88	191	279	367
	457.2	5	6.5	13	19	25
20	20.000	65	88	176	249	367
	508.0	4.5	6	12	17	25
24	24.000	51	73	147	205	367
	609.6	3.5	5	10	14	25
28	28.000		58	117	176	367
	711.2		4	8	12	25
30	30.000		58	117	176	338
	762.0		4	8	12	23
32	32.000		51	110	161	323
	812.8		3.5	7.5	11	22
36	36.000		51	95	147	294
	914.4		3.5	6.5	10	20
42	42.000		44	80	147	249
	1066.8		3	5.5	10	17
48	48.000		36	73	102	220
	1219.2		2.5	5	7	15

For pressure ratings see **Selection Charts**.

The selection charts are used to select the proper type of STRAUB-FLEX or STRAUB-OPEN-FLEX coupling for the application pressure. Separate charts are used for the TYPE 2 and 3 designs.

For complete dimensional data, see Page 10 or please consult the factory, STRAUB Technical Manual, or an authorized STRAUB Distributor.

Other sizes available upon request.

*STRAUB-FLEX is also available in a two-piece construction - useful for very tight spaces and for ease of handling.

STRAUB-OPEN-FLEX 2 couplings are available in two different styles depending on model and size:

- Slotted Casing
- 2-Piece Execution

STRAUB-OPEN-FLEX gaskets are cut and riveted to casing.

Please consult your STRAUB professional for more information

STRAUB-FLEX 3 & STRAUB-OPEN-FLEX 3 COUPLING

For IPS Outside Diameter Pipe

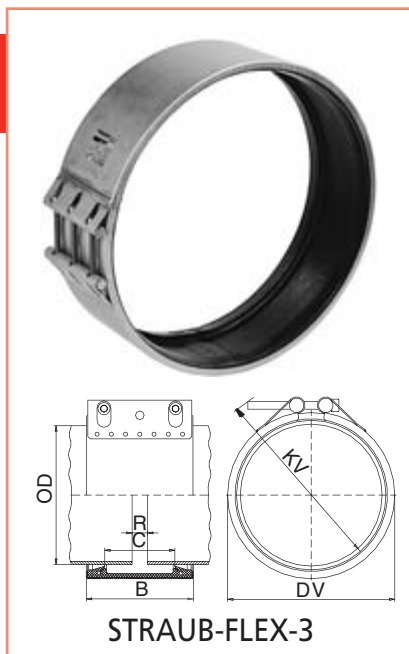

STRAUB-FLEX-3

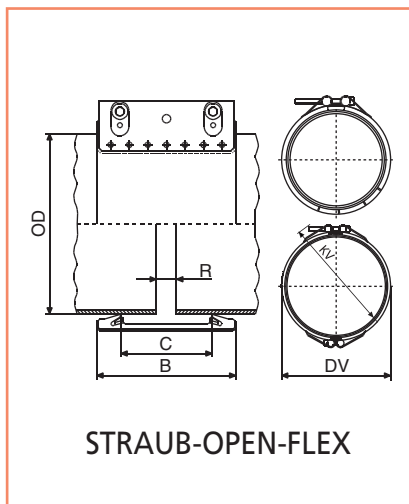

STRAUB-OPEN-FLEX

STRAUB-FLEX 3 & STRAUB-OPEN-FLEX 3 Selection Chart						
Nominal IPS Pipe Size (Inches)	Diameter In./mm	3L Working Pressure psi/bar	3LS Working Pressure psi/bar	3LU Working Pressure psi/bar	3H Working Pressure psi/bar	3X Working Pressure psi/bar
12	12.750 323.9	143 9.9	189 13.0	363 25.0		
14	14.000 355.6	119 8.2	160 11.0	363 25.0		
16	16.000 406.4	107 7.4	140 9.7	328 22.6	363 25.0	
18	18.000 457.2	95 6.6	125 8.6	292 20.1	363 25.0	
20	20.000 508.0	85 5.9	112 7.7	263 18.1	363 25.0	
24	24.000 609.6	71 4.9	94 7.0	203 14	251 17.3	363 25.0
28	28.000 711.2	59 4.1	81 5.6	174 12	218 15.0	363 25.0
30	30.000 762.0	55 3.8	74 5.1	160 11	203 14.0	363 25.0
32	32.000 812.8	55 3.8	71 4.9	152 10.5	189 13.0	363 25.0
36	36.000 914.4	46 3.2	64 4.4	123 8.5	187 11.5	334 23.0
42	42.000 1066.8	39 2.7	54 3.7	107 7.3	145 10.0	261 18.0
48	48.000 1219.2	34 2.3	51 3.5	94 6.5	123 8.5	247 17.0
54	54.000 1371.6	30 2.1	42 2.9	81 5.5	113 7.5	223 15.4
60	60.000 1524.0	26 1.8	36 2.5	73 5.0	102 7.0	203 14.0
66	66.000 1676.4	22 1.5	36 2.4	60 4.1	89 6.0	182 12.5
72	72.000 1828.8	20 1.3	29 2.0	51 3.5	80 5.5	160 11.0

For complete dimensional data, see Page 10 or please consult the factory, STRAUB Technical Manual, or an authorized STRAUB Distributor.

STRAUB-FLEX-3 & STRAUB-OPEN FLEX-3 are designed with 3-BOLTS

Other sizes available upon request.

STRAUB-OPEN-FLEX 3 couplings are available in two different styles depending on model and size:

- Slotted Casing
- 2-Piece Execution

OPEN-FLEX gaskets are cut and riveted to casing

Please consult your STRAUB professional for more information

Non-Axial Restraint Pipe Couplings

- Pipes must be properly anchored and supported.
- STRAUB-FLEX & STRAUB-OPEN-FLEX Couplings are NOT pull-out resistant.



All STRAUB couplings require the correct use of a torque wrench for a safe and proper installation. STRAUB couplings must be torqued to the specified value as printed on each individual coupling. Failure to do so can result in injury or death.

STRAUB-FLEX & STRAUB-OPEN-FLEX COUPLING

NEW PRODUCTS: CONSULT FACTORY FOR COUPLING & FITTING TOLERANCES

1" = 25.4mm

1 bar = 14.7 psi

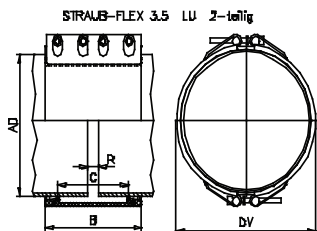

STRAUB-FLEX-3.5

DV = Outside diameter of the assembled pipe joint (mm) = OD + 38mm

B = Width of the pipe joint (mm)

FLEX 3.5LU = 310mm

FLEX 3.5H = 311mm

C = Distance between sealing lips = 227mm

Rmax. = Distance between pipe ends

Rmax. with strip insert = 120mm

Rmax. without strip insert = 20mm

Non-Axial Restraint Pipe Couplings

- Pipes must be properly anchored and supported.
- STRAUB-FLEX 3.5 & STRAUB-FLEX 4 Couplings are NOT pull-out resistant.

Other sizes available upon request.

STRAUB-FLEX 3.5 & STRAUB-OPEN-FLEX 3.5 Selection Chart

Pipe OD (mm)	Clamping range (mm)	Working Pressure PS		Torque rate		Locking bolts	
		FLEX 3.5 LU (bar)	FLEX 3.5 H (bar)	FLEX 3.5 LU (Nm)	FLEX 3.5 H (Nm)	FLEX 3.5 LU	FLEX 3.5 H
323.9	320 - 327	18	25	30	30		
355.6	352 - 359	17	25	30	30		
406.4	403 - 409	15	22	30	30		
457.2	454 - 460	13	21	30	30		
508.0	505 - 512	12	20	30	40		
558.8	555 - 562	11	19	40	40		
609.6	606 - 613	10	17	40	40		
655.0	652 - 658	9	16	40	40		
711.2	707 - 715	9	15	40	40		
762.0	758 - 766	8	14	40	50	4 x M16 with socket head 14 mms	4 x M16 with socket head 14 mm
812.8	809 - 817	8	13	40	50		
914.4	910 - 918	7	12	50	60		
1016.0	1012 - 1020	6	11	50	60	8x M16 for 2 pcs. type	8x M16 for 2 pcs. type
1117.6	1113 - 1122	6	10	60	70		
1219.2	1215 - 1224	5	9	60	70		
1422.4	1418 - 1427	4	8	70	80		
1524.0	1519 - 1529	4	7	80	90		
1625.0	1621 - 1631	4	7	80	100		
1727.2	1722 - 1732	3	6	90	100		
1828.8	1824 - 1834	3	6	90	110		
1930.4	1925 - 1935	3	5	100	110		
2032.0	2027 - 2037	2	5	100	120		

Available for all pipe sizes from 558.8 mm up to 3000.0 mm (larger and smaller ø to special order)

For Both	Components / Materials	W1	W2	W4	W5
STRAUB-FLEX 3.5	Casing	AISI 1024, hot-dip galv.	AISI 316 Ti / AISI 304	AISI 304	AISI 316 Ti
	Screws	AISI 4135**	AISI 4135**	AISI 316 L	AISI 316 L
& STRAUB-FLEX 4	Bolts	AISI 12L 14, galvanized	AISI 12L 14, galvanized	AISI 316 L	AISI 316 L
	Strip insert (option)	AISI 316 L / HDPE	AISI 316 L / HDPE	AISI 316 L / HDPE	AISI 316 L / HDPE
STRAUB-FLEX 3.5	Sealing sleeve	Temp.: -20° C up to +80° C			
ONLY	EPDM	Medium: all qualities of water, waste water, air, solids and chemical products			
	Sealing sleeve	Temp.: 20° C up to +80° C			
	DBR	Medium: water, gas, oil, fuel and other hydrocarbons			
STRAUB-FLEX 4	Sealing sleeve	Temp.: -20° C up to +80° C			
ONLY	EPDM NSF 61	Medium: all qualities of water, waste water, air, solids and chemical products			

STRAUB-FLEX 4 & STRAUB-OPEN-FLEX 4 Selection Chart

Pipe OD (mm)	Clamping range (mm)	Working Pressure PS		Torque rate		Locking bolts	
		FLEX 4 LU (bar)	FLEX 4 H (bar)	FLEX 4 LU (Nm)	FLEX 4 H (Nm)	FLEX 4 LU	FLEX 4 H
323.9	320 - 327	18	25	30	60	12 x M20 with socket head	12 x M20 with socket head
609.6	606 - 613	10	14	40	60		
762.0	758 - 766	8	11	40	80	17mms	17mm
1670.0	1666 - 1674	4	5	80	100		

Available for all pipe sizes from 323.9 mm up to 3000.0 mm (larger and smaller ø to special order)

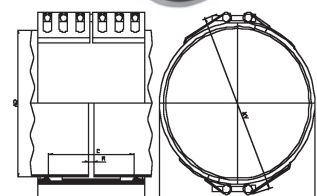

STRAUB-FLEX 4

DV = Outside diameter of the assembled pipe joint (mm) = OD + 48 mm

KV = OD + 90

B = Width of the pipe joint (mm)

FLEX 4LU = 444 mm

FLEX 4H = 445 mm

C = Distance between sealing lips = 353 mm

Rmax. = Distance between pipe ends

Rmax. with strip insert = 200 mm

Rmax. without strip insert = 20 mm

Legend: - W1 - W5 according to DIN Standard 86128 (ASTM F 1476 / F1548, ISO/INP-15837 / 15838).

** Property class 12.9, Dacromet 500 (zinc-chromate with integrated lubricant).

Remarks: - Available in 2 pc. only

- Follow fitting / disassembly instructions.

- Test pressure = 1,5 x working pressure

- Admissible maximum axial movement of the pipes DI : 20 mm.

- Strip insert are required when the gap between the pipe ends is excessive, in presence of swelling, at vacuum/depression (suction line), or external pressure. Strip inserts are available, under separate order, at additional costs.

STRAUB-IRON-GRIP COUPLINGS

For AWWA Ductile Iron Pipe Sizes

Axial Restraint Pipe Couplings

Fits:

Ductile Iron & C-900 Pipe OD's

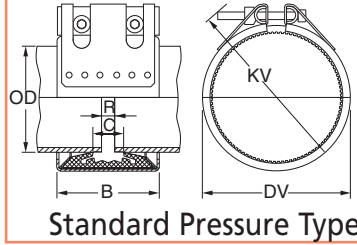

Standard Pressure Type

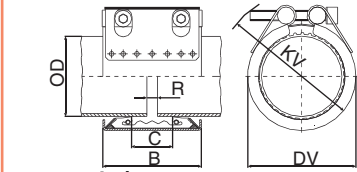

High-Pressure Type

STRAUB-IRON GRIP (DUCTILE IRON SIZE)

Nominal Ductile Iron Pipe Size	PIPE OUTSIDE DIAMETER		Working Pressure	COUPLING DIMENSIONS		ASSEMBLED DIMENSIONS		Maximum Distance Between Pipe Ends (R _{max})		Torque Rate	Approx. Weight Each
	Actual	OD Range		B	C	DV	KV	Strip insert	In./mm		
Inches	In./mm	In./mm	psi/bar	In./mm	In./mm	In./mm	In./mm	In./mm	In./mm	Ft.lbs./Nm	Lbs./kg
6	6.900	6.83 - 6.97	200	4.33	2.13	8.46	9.65	0.4	1.4	30	7
	175.3	173.4 - 177.0	13.8	110	54	215	245	10	35	40	3.2
8	9.050	8.96 - 9.14	150	5.59	3.15	10.43	11.81	0.4	1.4	45	14
	229.9	227.5 - 232.1	10.3	142	80	265	300	10	35	60	6.5
10*	11.100	11.00 - 11.20	250	5.83	2.64	13.39	14.96	0.6	1.4	135	34.5
	281.9	279.4 - 284.4	17.2	148	67	340	380	15	35	180	15.7
12*	13.200	13.08 - 13.32	250	5.83	2.64	15.94	17.13	0.6	1.4	170	39
	335.3	332.2 - 338.3	17.2	148	67	405	435	15	35	230	17.8
14*	15.300	15.16 - 15.44	200	5.83	2.64	18.31	19.29	0.6	1.4	170	44.0
	388.6	385.0 - 392.1	13.8	148	67	465	490	15	35	230	20.0
16*	17.400	17.25 - 17.55	200	5.83	2.64	20.87	21.46	0.6	1.4	185	56.5
	442.0	438.1 - 445.7	13.8	148	67	530	545	15	35	250	25.5
18*	19.500	19.31 - 19.69	150	6.02	2.64	21.65	23.43	0.6	1.4	185	62.9
	495.3	490.4 - 500.1	10.3	153	67	550	595	15	35	250	28.6
20*	21.600	21.40 - 21.80	150	6.02	2.64	24.02	25.59	0.6	1.4	220	69
	548.6	543.5 - 553.7	10.3	153	67	610	650	15	35	300	31.2
24*	25.800	25.60 - 26.00	100	6.02	2.64	28.74	29.72	0.6	1.4	220	81.6
	655.3	650.2 - 660.4	6.9	153	67	730	755	15	35	300	37.1

* Indicates "high-pressure" type - available with galvanized casings only.

Other sizes and pressure ratings available in stainless steel - consult factory for information.

6" & 8": W2 standard
W5 on request

10" - 24" W1 Standard

STRAUB-FLEX & STRAUB-OPEN-FLEX COUPLINGS

For AWWA Ductile Iron Pipe Sizes

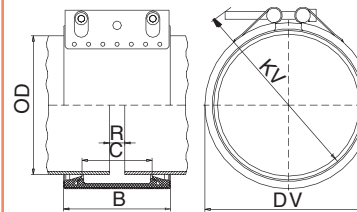

STRAUB-FLEX

STRAUB-FLEX 1L & STRAUB-OPEN-FLEX 1L Dimensions

Nominal Ductile Iron Pipe Size	PIPE OUTSIDE DIAMETER		Working Pressure	COUPLING DIMENSIONS		ASSEMBLED DIMENSIONS		Maximum Distance Between Pipe Ends (R _{max})		Approx. Weight Each
	Actual	OD Range		B	C	DV	KV	Without Strip insert	With Strip insert	
Inches	In./mm	In./mm	psi/bar	In./mm	In./mm	In./mm	In./mm	In./mm	In./mm	Lbs./kg
4	4.800	4.75 - 4.84	232	5.5	3.6	5.51	6.30	0.2	1.0	2.5
	121.9	120.9 - 122.9	16.0	94	51	140	160	5	25	1.1
6	6.900	6.82 - 6.97	232	5.5	3.6	8.07	8.46	0.2	1.4	3.8
	175.3	173.4 - 177.0	16.0	140	91	205	215	5	35	1.7

*W2 or W5

• Pipes must be properly anchored and supported.

• STRAUB-FLEX & STRAUB-OPEN-FLEX Couplings are NOT pull-out resistant.



All STRAUB couplings require the correct use of a torque wrench for a safe and proper installation. STRAUB couplings must be torqued to the specified value as printed on each individual coupling. Failure to do so can result in injury or death.

STRAUB-FLEX & STRAUB-OPEN-FLEX COUPLINGS

For AWWA Ductile Iron Pipe Sizes

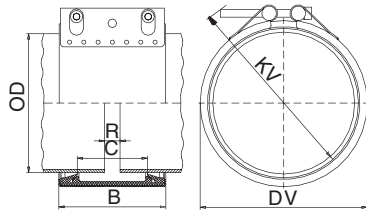

STRAUB-FLEX

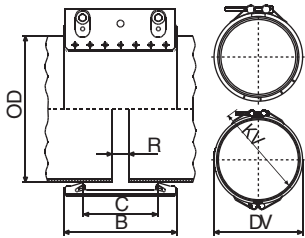

STRAUB-OPEN-FLEX 2
(2-piece execution shown)

Non-Axial Restraint Pipe Couplings

*W1, W2, or W5
Consult Factory for details

- Pipes must be properly anchored and supported.
- STRAUB-FLEX & STRAUB-OPEN-FLEX Couplings are NOT pull-out resistant.



All STRAUB couplings require the correct use of a torque wrench for a safe and proper installation. STRAUB couplings must be torqued to the specified value as printed on each individual coupling. Failure to do so can result in injury or death.

STRAUB-FLEX 2 & STRAUB-OPEN-FLEX 2 Selection

Nominal Ductile Iron Pipe Sizes	Pipe Outside Diameter	2L Working Pressure	2LS Working Pressure	2LU Working Pressure	2H Working Pressure	2XS Working Pressure
Inches	In./mm	psi/bar	psi/bar	psi/bar	psi/bar	psi/bar
8	9.050 229.9	145 10	196 13.5	363 25.0		
10	11.100 281.9	116 8	160 11.0	319 22		
12	13.200 335.3	102 7	145 10.0	280 19.3	290 20.0	
14	15.300 388.6	87 6	123 8.4	230 15.8	290 20.0	
16	17.400 442.0	80 5.5	109 7.5	210 14.4	287 19.8	290 20.0
18	19.500 495.3	73 5	94 6.4	174 12.0	260 17.9	290 20.0
20	21.600 548.6	65 4.5	80 5.5	152 10.4	235 16.2	290 20.0
24	25.800 655.3	51 3.5	70 4.8	145 10	197 13.6	290 20.0
30	32.000 812.8	50 3.4	50 3.4	109 7.5	148 10.2	290 20.0
36	38.300 972.8	45 3.1	45 3.1	85 5.8	125 8.6	290 20.0
42	44.500 1130.3	35 2.4	35 2.4	80 5.5	105 7.2	290 20.0

STRAUB-FLEX 3 & STRAUB-OPEN-FLEX 3 Selection

Nominal Ductile Iron Pipe Sizes	Pipe Outside Diameter	3L Working Pressure	3LS Working Pressure	3LU Working Pressure	3H Working Pressure	3X Working Pressure
(Inches)	In./mm	psi/bar	psi/bar	psi/bar	psi/bar	psi/bar
12	13.200 335.3	143 9.9	189 13.0	363 25.0		
14	15.300 388.6	119 8.2	160 11.0	363 25.0		
16	17.400 442.0	105 7.2	140 9.7	328 22.6	363 25.0	
18	19.500 495.3	95 6.6	123 8.5	292 20.1	363 25.0	
20	21.600 548.6	85 5.9	110 7.6	263 18.1	363 25.0	
24	25.800 655.3	71 4.9	94 7.0	203 14	251 17.3	363 25.0
30	32.000 812.8	55 3.8	74 5.1	160 11	203 14.0	363 25.0
36	38.300 972.8	46 3.2	64 4.4	123 8.5	167 11.5	334 23
42	44.500 1130.3	39 2.7	54 3.7	107 7.3	145 10.0	261 18
48	50.800 1290.3	34 2.3	51 3.5	94 6.5	123 8.5	247 17
54	57.560 1462.0	30 2.1	42 2.9	81 5.5	113 7.8	223 15.4
60	61.610 1564.9	26 1.8	36 2.5	73 5.0	102 7.0	203 14
72	75.340 1913.6	20 1.3	29 2.0	51 3.5	80 5.5	160 11



**STRAUB-GRIP-L
for Copper Tube**

STRAUB COUPLINGS FOR COPPER TUBE

Axial Restraint Pipe Couplings

- Pipes must be properly anchored and supported.
- STRAUB-FLEX & STRAUB-OPEN-FLEX Couplings are **NOT** pull-out resistant.

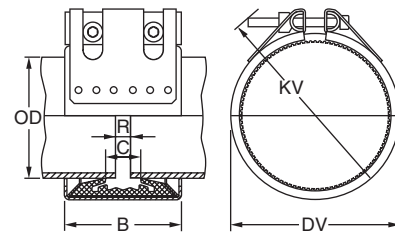

STRAUB-GRIP-L Copper Tube Sizes (CTS)

Nominal Tubing Size	PIPE OUTSIDE DIAMETER		Working Pressure	COUPLING DIMENSIONS				ASSEMBLED DIMENSIONS		Maximum Distance Between Pipe Ends (Rmax.)		Approx. Weight Each
	Actual	OD Range +/-		B	C	DV	KV	Without	With	Torque Rate		
	Inches	In./mm						In./mm	In./mm		In./mm	
2"	2.125	2.10 - 2.15	250	3.0	1.5	3.0	4.1	0.4	0.6	10	1.1	
	54.0	53.5 - 54.5		76	37	75	105	10	15			0.5
2½"	2.625	2.55 - 2.65	390	3.7	1.4	3.5	5.0	0.4	0.6	10	1.54	
	66.6	64.9 - 67.3		94	36	89	127	10	15			0.7
3"	3.125	3.09 - 3.16	333	3.7	1.4	4.0	5.4	0.4	0.6	10	2.86	
	79.4	78.7 - 80.3		94	36	102	137	10	15			1.3
4"	4.125	4.08 - 4.17	250	3.7	1.4	5.3	6.1	0.4	1.0	10	3.3	
	104.8	103.8 - 105.8		94	36	135	155	25	1.5			
6"	6.125	6.06 - 6.19	200	4.3	1.9	7.3	8.3	0.4	1.2	10	6.6	
	155.6	154.1 - 157.1		110	48	185	210	30	3.0			
8"	8.125	8.04 - 8.20	100	5.5	3.1	9.3	10.4	0.4	1.4	10	12.1	
	206.4	204.4 - 208.4		140	80	235	264	35	12.1			

*W5 only

See label on coupling for proper torque rates

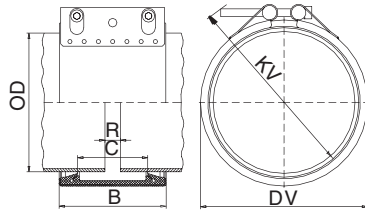

STRAUB-FLEX for Copper Tube

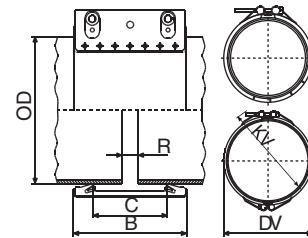

STRAUB-OPEN-FLEX for Copper Tube

Non-Axial Restraint Pipe Couplings

STRAUB-FLEX Copper Tube Sizes (CTS)

Nominal Tubing Size	PIPE OUTSIDE DIAMETER		Working Pressure	COUPLING DIMENSIONS				ASSEMBLED DIMENSIONS		Maximum Distance Between Pipe Ends (Rmax.)		Approx. Weight Each
	Actual	OD Range +/-		B	C	DV	KV	Without	With	Torque Rate		
	Inches	In./mm						In./mm	In./mm		In./mm	
2"	2.125	2.10 - 2.15	232	3.0	1.4	3.0	3.5	0.4	0.6	5	1.21	
	54.0	53.5 - 54.5		75	35	75	90	15	0.58			
2½"	2.625	2.55 - 2.65	232	3.0	1.4	3.0	3.5	0.4	0.6	5	1.3	
	66.6	64.9 - 67.3		75	35	75	90	15	0.59			
3"	3.125	3.09 - 3.16	232	3.0	1.4	3.0	3.5	0.4	0.6	5	2.1	
	79.4	78.7 - 80.3		75	35	75	90	15	0.95			
4"	4.125	4.08 - 4.17	232	3.7	2.0	4.9	5.5	0.2	1.0	5	2.3	
	104.8	103.8 - 105.8		94	51	125	140	25	1.04			
6"	6.125	6.06 - 6.19	232	4.2	2.4	6.9	7.7	0.2	1.4	5	3.55	
	155.6	154.1 - 157.1		107	62	175	195	35	1.61			
*8"	8.125	8.04 - 8.20	150	5.5	3.1	9.3	10.4	0.4	1.4	10	6.0	
	206.4	204.4 - 208.4		140	80	235	264	35	2.72			

*W2, or W5

Consult Factory for details



All STRAUB couplings require the correct use of a torque wrench for a safe and proper installation. STRAUB couplings must be torqued to the specified value as printed on each individual coupling. Failure to do so can result in injury or death.

DIMENSIONS AND MINIMUM PIPE WALL THICKNESS

1 mm = .03937 in

Pipe Diameter		Pipe OD		Minimum Wall Thickness	
IPS	Metric	IPS	Metric	Stainless Steel STRAUB-GRIP-L & METAL-GRIP	Copper-Nickel CuNi Class 200 STRAUB-GRIP-L
(Nominal)	(DIN Std.)	inch	mm	mm	in/mm
¾	20	1.050	26.9	1.5	.04/1.02
	25	1.180	30.0	1.5	
1	25	1.325	33.7	1.5	.05/1.27
	32	1.495	38.0	1.5	
1¼	32	1.670	42.4	1.5	.05/1.27
	40	1.750	44.5	1.5	
1½	40	1.900	48.3	1.5	.05/1.27
	50	2.125	54.0	1.5	
	50	2.245	57.0	1.5	
2	50	2.375	60.3	1.5	.06/1.52
	65	2.625	66.6	2.0	
	65	2.756	70.0	2.0	
2½	65	2.875	73.0	2.0	.07/1.78
	65	3.000	76.1	2.0	
	65	3.125	79.4	2.0	
	80	3.305	84.0	2.0	
3	80	3.500	88.9	2.0	.08/2.03
3½	80	3.960	100.6	2.0	.08/2.03
	90	4.000	101.6	2.0	
	100	4.095	104.0	2.0	
	100	4.125	104.8	2.0	
	100	4.250	108.0	2.0	
4	100	4.500	114.3	2.0	.09/2.29
	100	5.000	127.0	2.3	
	125	5.080	129.0	2.3	
	125	5.125	130.2	2.3	
			131.0*	3.0	
	125	5.235	133.0	2.3	
5	125	5.500	139.7	2.3	.10/2.54
	125	5.565	141.3	2.3	
	150	6.065	154.0	2.3	
			155.6*	2.5	
	150	6.260	159.0	2.3	
6	150	6.625	168.3	2.3	.12/3.05
	200	7.625	193.7	3.0	
			206.4		
8	200	8.625	219.1	3.0	.15/3.81
Minimum Wall Data Below For STRAUB-GRIP-L Only *					
	225	9.625	244.5	3.0	
	250	10.510	267.0	3.0	
10	250	10.750	273.0	3.0	.19/4.82
			306.0	3.0	
12	300	12.750	323.9	3.0	.22/5.50
14	350	14.000	355.6	3.0	.24/6.10
16	400	16.000	406.4	3.0	.27/6.86
18	450	18.000	457.2	3.0	.30/7.62
20	500	20.000	508.0	3.0	.33/8.38
22	550	22.000	558.8	3.0	.36/9.14
24	600	24.000	609.6	3.0	.40/10.16

standard IPS diameter *For STRAUB-METAL-GRIP data on these sizes please consult factory.

FORCES TO AVOID

STRAUB PIPE COUPLINGS

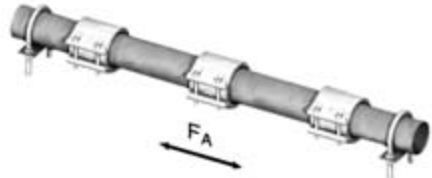
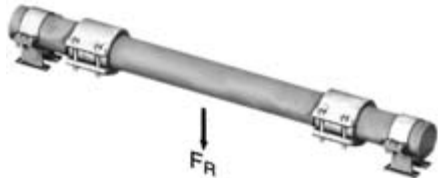
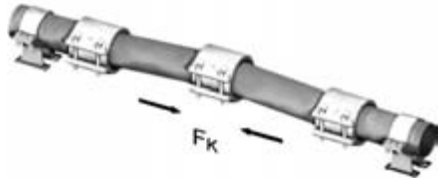
<h2 style="margin: 0;">Pull-Out Forces</h2>	<p>Axial Force (F_A)</p>  <p>OK for STRAUB-GRIP Type. Not resisted by STRAUB-FLEX/OPEN-FLEX</p>
<h2 style="margin: 0;">Sheer Loads* (consult factory for specific data)</h2>	<p>Weight (F_R)</p>  <p>Not resisted by STRAUB-FLEX or STRAUB-GRIP</p>
<h2 style="margin: 0;">Knee</h2>	<p>Buckling (F_k)</p>  <p>Not resisted by STRAUB-FLEX or STRAUB-GRIP. Pipes must be properly guided.</p>

*Please consult the factory or an authorized STRAUB Distributor for any installation or application questions.

COUPLING/PIPE COMPATIBILITY:

Pipe Materials	Stiffening Ring	STRAUB-METAL GRIP/ STRAUB-GRIP-L	STRAUB-FLEX/STRAUB- OPEN-FLEX	STRAUB-COMBI GRIP/ PLASTI GRIP	Remarks
HDPE, PP, Noryl	Required	-	Yes	Yes	For STRAUB-FLEX pipes must be properly anchored
PVC, ABS, CPVC, C900	-	Yes	Yes	Yes	Stiffening Ring required for temps above 90°F
CFK, CRP, FRP, GRP (Centrifugal wound pipes)	-	-	Yes	-	Seal pipe surface at the cutting edge
Asbestos cement	-	-	Yes	-	
Concrete, CPP	-	-	Yes	-	Equalize rough surface with coating or filler
Cast (ductile, grey)	-	Yes	Yes	Yes	
Glass, Ceramic	-	-	Yes		
Copper-Nickel	-	Yes	Yes	Yes	Soft Copper with Stiffening Ring only
Aluminum	-	Yes	Yes	Yes	

INSTALLATION INFORMATION

STRAUB PIPE COUPLINGS INSTALLATION AND REMOVAL INSTRUCTIONS

INSTALLATION

Do not disassemble coupling.
Coupling comes ready to install.
Cut pipes to desired lengths.
Clean and de-burr pipe ends.
Pipes must be properly supported.
Center coupling over gap between pipe ends.
Do not exceed maximum allowed gap between pipe ends.
Using a torque wrench, tighten bolts to torque value printed on coupling. Insure that all bolts have been correctly torqued.



REMOVAL

Make sure there is no pressure or product in the system.
Loosen bolts. Do not remove bolts completely.
Carefully pry up and tap casing to release grip ring and gasket from pipe surface.
Slide coupling to side for removal.

CAUTION

Do not attempt to move coupling over pipe after tightening.
After coupling has been correctly installed, do not re-torque.
Do not hang weight of pipe in coupling.
Insure that pipes are properly supported.
STRAUB-FLEX Type couplings require anchored pipes.
STRAUB-FLEX Type couplings are not pull out resistant.

IMPORTANT APPLICATION INFORMATION

- ◆ A strip insert is required for vacuum service or for external pressure. See Column 6 for maximum gap requirements.
- ◆ STRAUB couplings are assembled with an internal silicone lubricant, special order when silicone-free product is required.
- ◆ STRAUB couplings are not designed to accommodate shear loading, or rotational (torsional) pipe movement. The weight of the pipe and contents must be supported. Only "STRAUB-GRIP" type couplings provide axial restraint.
- ◆ STRAUB-FLEX type couplings "DO NOT PROVIDE FOR AXIAL TYPE RESTRAINT". When using STRAUB-FLEX type couplings, pipes must be properly anchored and supported.
- ◆ All STRAUB couplings require the correct use of a torque wrench for a safe and proper installation. STRAUB couplings must be torqued to the specified value as printed on each individual coupling. Failure to do so can result in injury or death.

CONDUCTIVITY CLIPS

STRAUB-GRIP type couplings are conductive by design. STRAUB-FLEX type couplings require the use of STRAUB Conductivity Clips to insure electric current continuity between pipes. Conductivity Clips are not standard and must be ordered separately.

STRIP INSERTS

Strip inserts need only be used if required. Strip inserts protect the sealing sleeve against mechanical or chemical damage in the pipe gap area. Strip inserts are required when the distance between pipe ends is excessive or when axial movement is combined with angular deflection or axial "misalignment". The installation can be pre-fitted for all pipe coupling types. Strip inserts are also required for vacuum service or when aggressive media may be expected to degrade the rubber gasket. Selection of insert material to be dictated by the medium.

"T" type inserts (shown) also available for special applications.

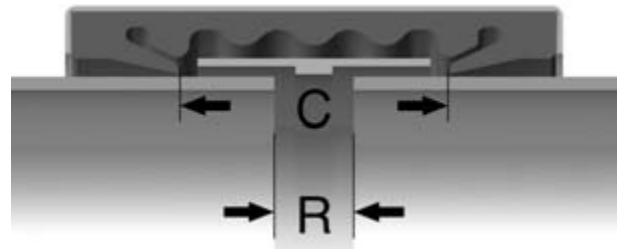

All STRAUB couplings require the correct use of a torque wrench for a safe and proper installation. STRAUB couplings must be torqued to the specified value as printed on each individual coupling. Failure to do so can result in injury or death.

FITTING TOLERANCES

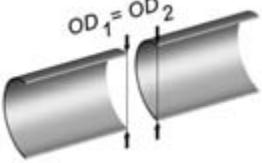
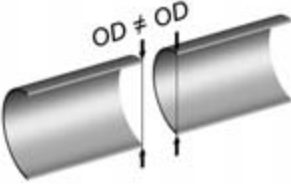
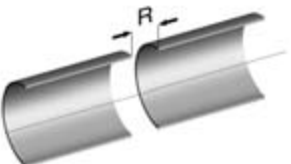
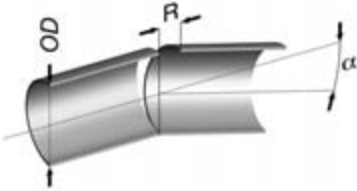
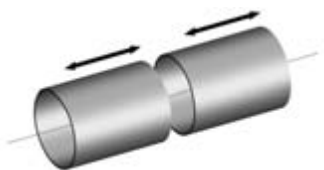
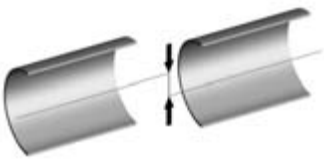
1		<p>Clamping Range</p> <p>Connecting of two pipes with same outside diameter.</p>
2		<p>Different Diameters</p> <p>Connecting of two pipes with different outside diameter.</p>
3		<p>Setting Gap Between Pipe Ends R</p> <p>Connecting of two pipes with or without setting gap [R].</p>
4		<p>Angular Deflection α</p> <p>Setting gap between pipe ends through angular deflection. Maximum angular deflection (dynamic and static).</p>
5		<p>Axial Movement Δl</p> <p>STRAUB-FLEX/OPEN-FLEX couplings are pipe connectors and expansion joints combined into one unit.</p>
6		<p>Axial Misalignment</p> <p>Connecting of two pipes with axial misalignment. Maximum allowed 1% of outside diameter (max. 3 mm).</p>

----> For Approximate values see chart on the next page

FITTING TOLERANCES

Approximate Values for fitting tolerances.

1 mm = .03937 in

STRAUB Type		Pipe OD	1 Clamping range per OD	2 Different diameters	3 Setting gap between pipe ends R	
					without	with
		Strip insert		mm	mm	
		OD-Range mm	+/- mm / %	mm / %	mm	mm
STRAUB-METAL-GRIP		33.7 - 54.0	0.5 mm	2 mm	5	15
		57.0 - 88.9	1.0%	2 mm	10	25
		104.0 - 114.3	1.0%	2%	10	25
		133.0/139.7/159.0/168.3	1.0%	2%	15	30
		129.0/154.0/219.1/273.0	1.0%	2%	15	35
		323.9 - 609.6	1.0%	6 mm	15	35
STRAUB-GRIP-L		26.9 - 33.7	1.0%	2 mm	5	5
		38.0 - 48.3	1.0%	2 mm	5	10
		54.0 - 60.3/84.0	1.0%	2 mm	10	15
		73.0/76.1/88.9	1.0%	2 mm	10	25
		100.6 - 104.8	1.0%	2%	10	15
		108.0/114.3	1.0%	2%	10	25
		154.0	1.0%	2%	10	30
		127.0 - 141.3/159.0 - 273.0	1.0%	2%	10	35
		304.0-609.8	1.0%	6 mm	10	35
STRAUB-FLEX 1	STRAUB-OPEN-FLEX 1	48.3 - 60.3	0.5%	2	5	15
		76.1 - 88.9	1.0%	2	5	25
		100.6 - 114.3	1.0%	2%	5	25
		127.0 - 168.3	1.0%	2%	5	35
STRAUB-FLEX 2	STRAUB-OPEN-FLEX 2	180.0 - 300.0	1.0%	2%	10	35
		301.0 - 1219.2	3 mm	6 mm	10	35
STRAUB-FLEX 3		558.8 - 2032.0	3 mm	6 mm	15	60
STRAUB-OPEN-FLEX 3		558.8 - 1219.2	3 mm	6 mm	15	60

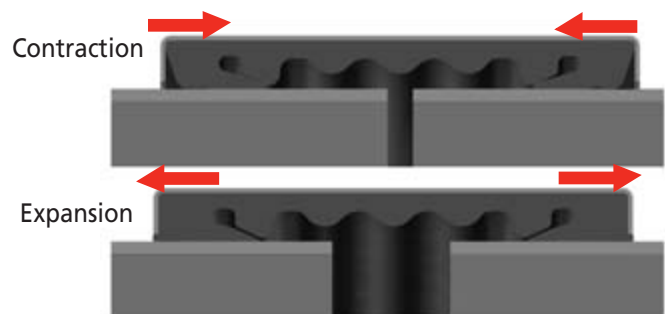
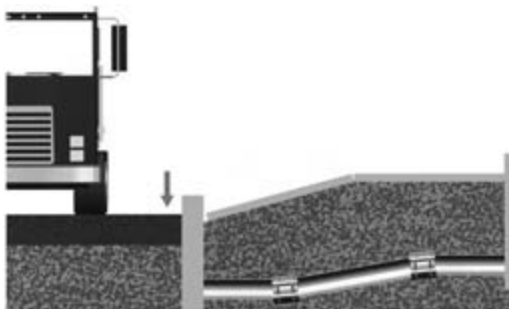

4 Angular Deflection		
Outside Diameter OD mm		Degree
GRIP	FLEX/OPEN-FLEX	
≤ 60.3mm	≤ 60.3mm	5
60.3 mm - 219.1 mm	60.3 mm - 219.1 mm	4
≥ 219.1mm	≥ 219.1mm	2

5 Max. Axial Movement	
STRAUB-Type	mm/in
FLEX 1/OPEN-FLEX 1	5 mm/.2"
FLEX 2/OPEN-FLEX 2	10 mm/.4"
FLEX 3/OPEN-FLEX 3	15mm/.6"
FLEX 3.5/OPEN-FLEX 3.5	15mm
FLEX 4/OPEN-FLEX 4	20mm/.8"

INSTALLATION TIMES AND DIMENSION COMPARISON

The installation time includes:

- Marking of half the coupling width on both pipe ends.
- Fitting the coupling over pipe ends and correct alignment.
- Tightening the bolts with a torque wrench.



Nominal Pipe Size		Pipe O.D.		Fitting Time Per Coupling min
IPS Nominal	Metric DIN Std.	IPS inch	Metric mm	
0.75	20	1.050	26.7	2
-	25	1.180	30.0	2
1.00	25	1.325	33.7	2
-	32	1.495	38.0	2
1.25	32	1.670	42.4	2
-	40	1.750	44.5	2
1.50	40	1.900	48.3	2
-	50	2.125	54.0	3
-	50	2.245	57.0	3
2.00	50	2.375	60.3	3
	65	2.625	66.6	4
2.50	65	2.875	73.0	4
-	65	(3.000)	76.1	4
-	65	3.125	79.5	4
-	80	3.305	84.0	4
3.00	80	3.500	88.9	4
	80	3.960	100.6	5
3 1/2	90	(4.000)	101.6	5
-	100	4.095	104.0	5
-	100	4.125	104.8	5
-	100	4.250	108.0	5
4.00	100	4.500	114.3	5
-	100	5.000	127.0	6
-	125	5.080	129.0	6
-	125	5.125	130.2	6
-	125	5.235	133.0	6
5	125	(5.500)	139.7	6
-	125	5.565	141.3	6
-	150	6.065	154.0	7
-	150	6.260	159.0	7
6	150	6.625	168.3	7
8	200	8.625	219.1	9
-	225	9.625	244.5	10
-	250	10.510	267.0	10
10	250	10.750	273.0	10
12	300	12.750	323.9	12
14	350	14.000	355.6	12
16	400	16.000	406.4	12
18	450	18.000	457.2	12
20	500	20.000	508.0	12
22	550	22.000	558.8	12
24	600	24.000	609.6	12

 standard IPS diameter

COUPLING SELECTION CHART

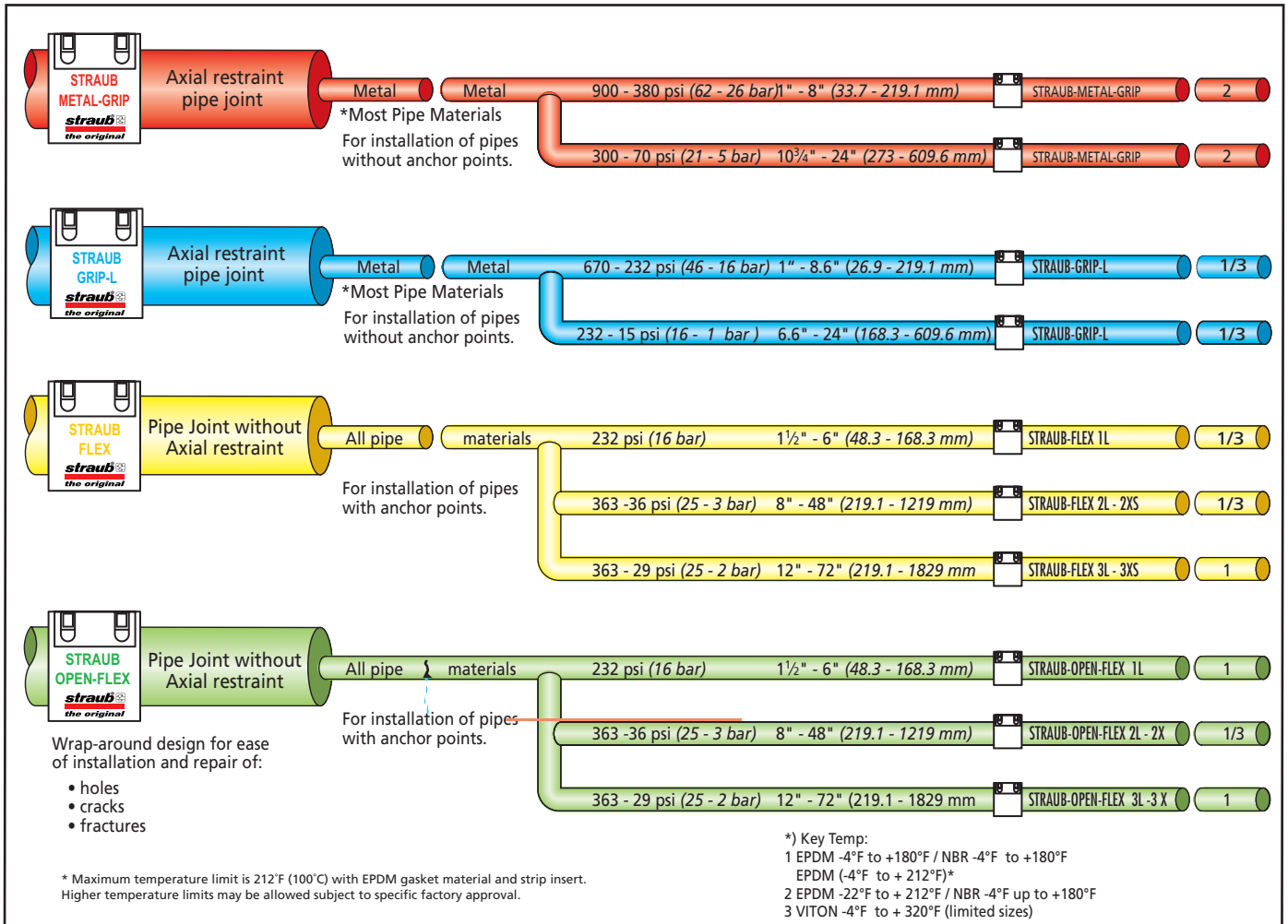

Other types available but not shown in this catalog. For more information, consult your STRAUB Professional or visit the website at www.straub-couplings.com



STRAUB-CLAMP



STRAUB-COMBI-GRIP



STRAUB-PLAST-GRIP



STRAUB-OPEN-FLEX GT



STRAUB-FIRE-FENCE

*Consult your STRAUB professional for complete details

straub®

the original

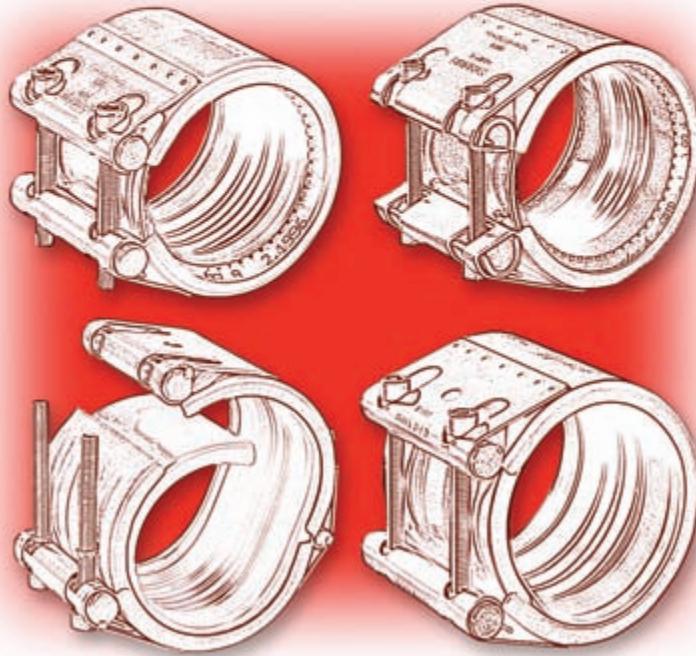

The materials and data in this catalogue are intended to assist the user in the proper selection of STRAUB Coupling products. STRAUB Pipe Couplings assumes no responsibility for any damage that might occur as a result of the use of any data, charts or application examples contained herein. All the information contained in this catalogue is subject to change by STRAUB Pipe Couplings without notice as a result of product re-designs, product improvements or other reasons.

STRAUB Pipe Couplings are designed for use under circumstances in which human life is potentially at risk. When considering the use of any product contained herein for special applications, please contact, STRAUB Werke A.G., Switzerland, or an authorized STRAUB distributor.

LIABILITY DISCLAIMER

The information contained herein may include inaccuracies or typographical errors. In addition, changes are periodically made to this information. STRAUB may make such changes to this information at any time without notice to the user.

STRAUB Pipe Couplings makes no representations about the suitability of the information contained herein for any purpose. All such information is provided as is without warranty of any kind. STRAUB Pipe Couplings disclaims all warranties with regard to this information. Under no circumstances shall STRAUB Pipe Couplings be liable for any direct, indirect, punitive, incidental, special or consequential damages arising out of or connected with the use of this information, whether based on contract, tort, strict liability or otherwise, even if STRAUB Pipe Couplings has been advised of the possibility of damages.

Corporate Office & Manufacturing Straub Werke A.G.

Rohrverbindungen • Straubstrasse 13
7323 Wangs, Switzerland
Tel: +41 81-725-4100
Fax: +41 81-725-4101
E-mail: straub@straub.ch
www.straub.ch



Performance Coupling Company

A DIVISION OF WESTFLEX INC.

2901 Harding Ave • National City, CA • 91950
Tel: 1-877-5-STRAUB (787282)
Tel: 619-336-0400
Fax: (619)-336-0458
E-mail: info@straubsales.com
www.straub-couplings.com

Marketing/Manufacturing Canada Straub Tadco Inc.

1239 Aerowood Drive • Mississauga
ON • L4W 1B9
Tel: 905-629-9114
Fax: 905-629-9116
E-Mail: info@straub.ca
www.straub.ca

DISTRIBUTED BY